

The information contained in this drawing is the sole property of CWS Coil Winding Specialist. Any reproduction in part or whole without written permission of CWS Coil Winding Specialist is prohibited.

REVISION HISTORY

REV	ECN	DESCRIPTION	SIGN & DATE			
			BY	DATE	CHK	DATE
B		PRODUCTION RELEASE	TDK	5/15/06	JLJU	5/15/06

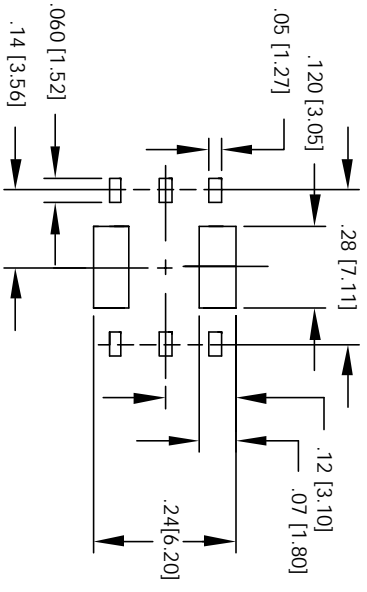
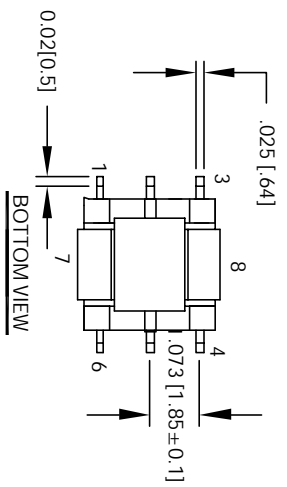
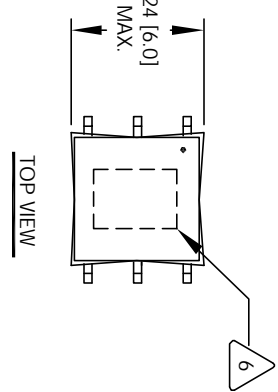
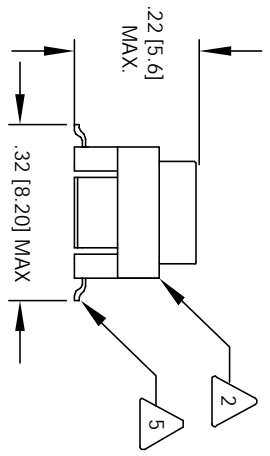
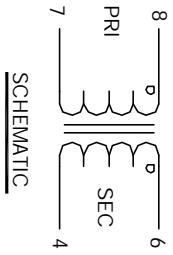

6 WHERE SHOWN  
MARK PART NUMBER AND REVISION

5 REMOVE INSULATION, SOLDERED TO LEADS

4 CONSTRUCTION: ENCAPSULATED USING BOBBIN.  
 FREQUENCY RANGE AT 100 KHZ AND ABOVE  
 OPERATING TEMP. = - 25 °C TO 125 °C  
 HI-POT PRIMARY TO SECONDARY = 500 Vrms  
 PRIMARY CURRENT = 6 A MAX.  
 SECONDARY DCR = 6.5 OHMS MAX  
 SECONDARY INDUCTANCE@ 10 KHZ, 0.1 V = 3000.0 uH MIN  
 TURNS RATIO PRI:SEC = 1:125  
 3 SPECIFICATIONS @ 25 °C:

2 WIRE: UL RECOGNIZED 130 °C RATED MAGNET WIRE  
 CWS BYTE-MARK OR OTHER APPROVED PART  
 CORE: FERRITE TOROID

1 BOBBIN RATING CLASS B (130 °C) REQUIRED  
 MATERIAL: UL RECOGNIZED 94V-0 FOR FLAMMABILITY  
 NOTES: UNLESS OTHERWISE SPECIFIED, CURRENT SENSOR.  
 UNIT: INCHES [MM]  
 READ FROM BOTTOM UP.

UNLESS OTHERWISE SPECIFIED
DIMENSIONING AND TOLERANCE PER ANSI Y14.4M
ALL DIMENSIONS ARE IN INCHES AND [DIMENSIONS]
TOLERANCE INCHES: .XXX = ±.010 .XX = ±.020 .X = ±.030
TOLERANCE METRCS: .XXX = ±.254 .XX = ±.51
ANGLE PROJECTION
DO NOT SCALE DRAWING

QTY	CODE	MFG. P/N	DESCRIPTION	ITEM NO.
	AUTOCAD	X		
	SOLIDWORKS			
	SIGN	DATE		
	DRAWN	5/15/06		
	CHKD	5/15/06		
	ENGR	5/15/06		
	APPR	5/15/06		
	JLJU			
	SCALE	4=1		
	SIZE	72-308		
	REV	B		
	SHEET	1	OF	1

Current Sense Transformer

COILWS.COM, INC  
 353 W. GROVE AVENUE  
 ORANGE, CA. 92665